

---

# Rectifier User Manual

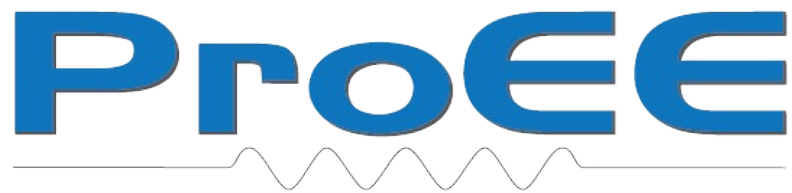

Version: 1.2

Model: PE-R

HF Rectifier module 24V/ 60A

## Catalogue

1. Electrical Specifications.....	3
1.1 Input Feature.....	3
1.2 Output Feature.....	3
1.2.1 Output voltage current regulation.....	3
1.2.2 Efficiency Figure.....	3

---

1.2.3 Output ripple and noise.....	4
1.2.4 Output dynamic response.....	4
1.2.5 Output Overshoot.....	4
1.2.6 Power Switch Point.....	4
1.2.7 Power on output delay time.....	5
1.2.8 LED indicator.....	5
1.2.9 Noise Voltage.....	6
1.2.10 Rectifier module and monitor module communication function.....	6
1.3 Protection Function.....	7
1.3.1 Output Limited Current Protection.....	7
1.3.2 Output short circuit Protection.....	7
1.3.3 Output Over Voltage Protection.....	7
1.3.4 Input Over Voltage Protection.....	7
1.3.5 Input under Voltage Protection.....	7
1.3.6 Over -Temp.Protection.....	7
2. Insulation Performance.....	8
2.1 Insulation resistance.....	8
2.2 Isolation Voltage.....	8
3. Safety standard.....	8
4. EMC.....	8
4.1 EMI.....	8
4.2 EMS.....	8
5. Working Environment.....	9
5.1 Ambient Temperature.....	9
5.2 Relative Humidity.....	10
5.3 Altitude.....	10
5.4 Cooling.....	10
5.5 Vibrate Tolerance.....	10
5.5.1 Working environment.....	10
5.5.2 Transportation environment.....	10
5.6 Impact Tolerance.....	10
5.7 Drop.....	10
6. Size.....	10
7. N.Weight.....	11
8. Chassis IP Protection Level.....	11
9. Transportation and storage.....	11
10. Other Requirement.....	11
11. MTBF.....	11
12. Connector PIN Definition.....	11
13. Product Maintenance.....	13
13.1 Product free maintenance time.....	13
13.2 On-site maintenance.....	13

# 1. Electrical Specifications

## 1.1 Input Feature

Input	Single input
Input Voltage Range	90Vac to 290Vac
Rate input Voltage	110Vac / 220Vac
Normal Input	100Vac to 240Vac
Frequency Range	45Hz-65Hz
Max Input Current	10.2A±10%@176Vac/1800W
Surge Current	Compliant Standard: ETSI300132-3
Efficiency	≥90%@220Vac@ 220Vac 100% load
PF	≥0.99@220Vac/60A
Leakage Current	<3.5mA@264Vac
Input Fuse	L Wire ,Fuse 25A
Max input Voltage	310Vac

## 1.2 Output Feature

### 1.2.1 Output voltage current regulation

Output Voltage	+24Vdc
Output Voltage Regulation	+24±0.1Vdc
Output Range adjustable Range	+21Vdc~+29Vdc
Load sharing ( 50%~100% Loading )	≤±5%
Line regulation	±0.1%
Load regulation	±0.5%
Voltage precision	±0.6%
Min-current	0A
Rate current	60A
Peaking current	65A
Tempe. coefficient ( 1/°C )	≤±0.02%
Rate Capacity	1800W(150Vac~290Vac) 1200W(90Vac~150Vac)

Note: The rectifier module output current regulation and communication interruption are as follows:

- 1.The output current of the rectifier module can be adjusted according to the current command. The adjustment range is 1A~60A.
- 2.Communication fault more than 1 minute (Rectifier and Control monitor),A .Rectifier module output Voltage automatic recovery default Voltage 24V and limited current function not working;b.if the rectifier modules are controller by monitor and Power off, then rectifier system will power on(if the rectifier fault, it can not be turned on again)

### 1.2.2 Efficiency Figure

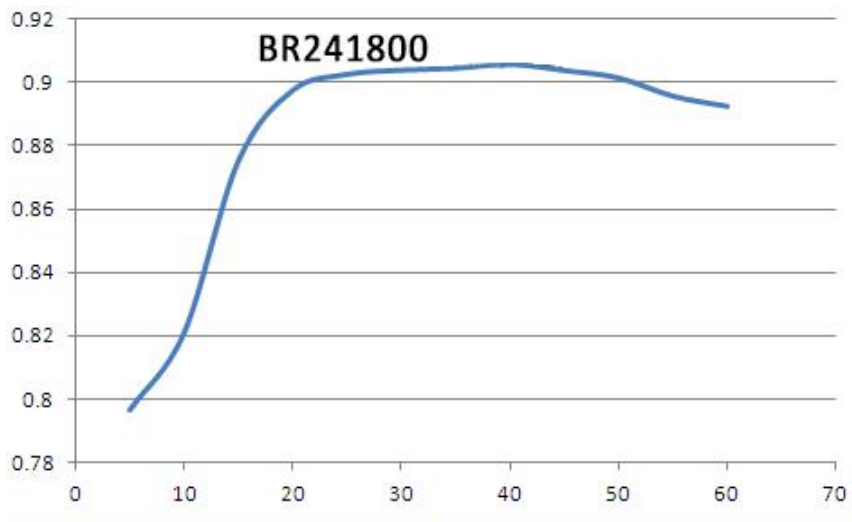

### 1.2.3 Output ripple and noise

Output Voltage	Ripple and Noise (Peaking-Peaking)
+24Vdc	200mVp-p@ 25°C, (Testing based on rate Input voltage & Output Voltage ,100% loading )

Note: Ripple and Noise testing:Ripple and noise Default as 20 MHz

### 1.2.4 Output dynamic response

Voltage overshoot	Adjustment slope	Loading	Voltage overshoot
+24V±5%	0.1A/uS	25% to 50% load 50% to 75%load	≤200us

Note: Adjustment slope Cycle 4ms

### 1.2.5 Output Overshoot

Output Voltage	Overshoot Voltage	
	On	off
+24V	≤5%	≤5%

Note:  
Loading Range Minimum to maximum.

### 1.2.6 Power Switch Point

Rated Switching Point	Min-Switching Point	Max-Switching Point
150Vac	145Vac	160Vac

Input Voltage --Power Capacity

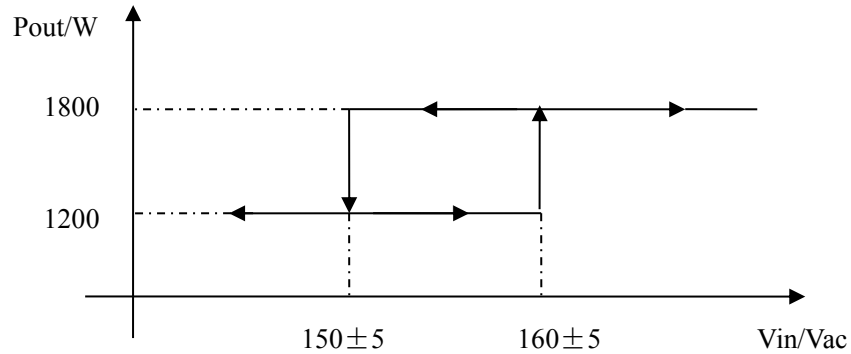

### 1.2.7 Power on output delay time

Output Voltage	220Vac@25°C
+24V	3S~10S

Note: The power-on delay time is the time from AC power-on to output voltage (to 23VDC)

### 1.2.8 LED indicator

The power LED is installed on the power panel side and the output status is shown in the table below.

Indicator	LED Color	NormalStatus	Abnormal status	Abnormal Reasons
Power running indicators	Green	<b>On</b>	off	
Protect indicators	Yellow	Off	<b>on</b>	Temperature pre-alarm (working temperature more than 65 °C ,then over temperature shutdown); Sleep shutdown (the module only lights the

				protection indicator when the system is shut down, and the module does not report alarm).
Fault Indicator	Red	Off	<b>on</b>	Output Over voltage power off、Fan fault、Over-Temp. Power off、Rectifier module inner fault。

### 1.2.9 Noise Voltage

Noise Voltage	Max	Note
Phone noise weighting Voltage	$\leq 2\text{mV}$	
broadband noise Voltage	$\leq 50\text{mV}$	3.4~150KHz
	$\leq 20\text{mV}$	0.15~30000KHz
Radio interference noise, or radio frequency noise	$\leq 5\text{mV}$	3.4~150KHz
	$\leq 3\text{mV}$	150~200KHz
	$\leq 2\text{mV}$	200~500KHz
	$\leq 1\text{mV}$	500~30000KHz

### 1.2.10 Rectifier module and monitor module communication function

RS485 communication mode (half-duplex, double-line) is adopted between the rectifier module and the monitoring module.

The RS485 interface in the rectifier module needs to be isolated. The RS485 power supply is +5Vdc (regulation accuracy  $\pm 5\%$ ), which is provided by the monitoring module.

The main monitoring information of the rectifier module is:

- 1) Adjust Voltage and Current function: meet the requirements of battery floating charge and meet the adjust voltage requirements;
- 2) Single module switch machine control;
- 3) Alarm information:  
Mains failure: mains failure (AC input over voltage);

---

Module protection: temperature pre-alarm;

Module failure: Output over voltage shutdown, fan failure, over temperature shutdown or no output caused by internal causes of other modules; (module is in: sleep shutdown state, mains failure does not report module failure).

### 1.3 Protection Function

#### 1.3.1 Output Limited Current Protection

Output Voltage	Limited Current point	Note
+24V	105%~110%	Limited current output

#### 1.3.2 Output short circuit Protection

Output Voltage	Note
+24V	Restart after Protection

#### 1.3.3 Output Over Voltage Protection

Output Voltage	Protection Point
+24V	33±2V. (Lock)

Note: After entering the lock protection state, you need to disconnect the AC power first, and then re-power on, the rectifier module can be re-operated.

#### 1.3.4 Input Over Voltage Protection

Input Voltage	Note
310±10Vac	Output off, Self-recovery after normal voltage
	output recovery point backlash>10V

Note: Input overvoltage protection should be tested at 50A rated load.

#### 1.3.5 Input under Voltage Protection

Input Voltage	Note
80±5Vac	Output is closed. Self-recovery after normal Voltage
	Output Recovery point backlash>5V

#### 1.3.6 Over -Temp.Protection

Temp.	Note
≤55℃	With maximum output Capacity ability , without over-temperature protection and the module is running normally.
55℃~65℃	The module can be automatically derate to ensure long-term stable output of at least 50% of rated power
>65℃	Power off, After power off,Recovery temperature difference >10℃

## 2. Insulation Performance

### 2.1 Insulation resistance

Input & output	Testing voltage 500VDC,Insulation Resistance ≥10M (normal atmospheric pressure, normal temperature, relative humidity <90%, no condensation)
Input & ground	
Output & ground	

### 2.2 Isolation Voltage

Input & output	DC Voltage 4240Vdc 1minute ≤30mA
Input & ground	DC Voltage 2120Vdc 1minute ≤30mA
Output & ground	DC Voltage 710Vdc 1minute ≤30mA

## 3. Safety standard

**Power supply safety meets the following standards:**

GB4943-2001

## 4. EMC

### 4.1 EMI

**1)Compliant with the the Below Standard:**

**Conduction Emission :**

\*EN55022/GB9254, CLASS A

**2) Radiated Emission :**

\*EN55022/GB9254, CLASS A

### 4.2 EMS

**The power supply shall compliance with the following Criterion:**

**1) ESD**

\*GB17626.2/IEC61000-4-2

a, the Chassis, the parts that can be touch during normal operation: contact discharge +/-6KV; air discharge +/-8KV, Criterion B (power on test)。

b, the Chassis , the parts that can be touch during normal operation: contact discharge +/-8KV; air discharge +/-10KV,



Criterion R (not powered during test).  
 c, signal interface inner conductor: contact discharge +/- 2KV  
 Criterion R; (power on test, no test on address line and current line)

**2) EFT**

\*GB17626.4/IEC61000-4-4                      Level 3              Standard: A

**3) SURGE**

\*GB17626.5/IEC61000-4-5                      Level 4              Standard: B

**4) DIP**

\*GB17626.11/IEC61000-4-11

Power DIP voltage drop requirement    Table (220Vac)

Drop to	Drop Phase	Drop Time	Standard
0%Ut	0°/45°/90°/135°/180°/225°/270°/315°	10ms	B
40%Ut	0°/45°/90°/135°/180°/225°/270°/315°	20ms	B
70%Ut	0°/45°/90°/135°/180°/225°/270°/315°	100ms	B

**5) Input harmonic current**

\*IEC 61000-3-2 [6]                                      CLASS A

**6) voltage fluctuations and flicker**

\*IEC 61000-3-3

$P_{st} \leq 1.0$ ;  $P_{1t} \leq 0.65$ ;  $d_c \leq 3\%$ ;  $d_{max} \leq 4\%$ ;  $d(t)$  more than 3% time  $\leq 200ms$

**7) lightning test**

In the system application, the AC input can withstand the impact current waveform of n more than 5 kA, 8/20us, positive and negative 5 times, each interval of 1 minute (see standard: YD 5098-2001)

**8) Immunity to conducted disturbances**

\*IEC61000-4-6                                      Level 3                      Standard: A

**9) Radiated interference**

\*IEC61000-4-3                                      Level 3                      Standard: A

**Testing Standard:**

A: The power supply did not have any degradation in performance throughout the test, and it was completely the same as the specifications specified in the power supply specification.

B: During the test, the performance of the power supply is allowed to temporarily decrease, but it can be restored after the test is over.

C: A short-term loss of function is allowed, but the end of the test can be restored automatically or manually.

R: Damage to other devices other than the fuse device is not allowed during the test.

**5. Working Environment**

5.1 Ambient Temperature

\*Working Temp.: -40°C to +55°C.

\*Storage Temp: -40°C to +70°C.

\*Transport Temp: -40°C to +70°C.

## 5.2 Relative Humidity

\*Working RH: 5%~95% (No condensation)

\*Storage RH: 5%~95% (No condensation)

## 5.3 Altitude

\*working Altitude: 0~4000M, based 2000m, For every 200 m increase in altitude, the temperature drops by 1°C

\*Storage Altitude : 0~4000M, based 2000m, For every 200 m increase in altitude, the temperature drops by 1°C

## 5.4 Cooling

\*The rectifier module with fan, forced air cooling, air is sent out after the wind is coming forward, the fan is placed in the front, and the fan has temperature control speed regulation function.

## 5.5 Vibrate Tolerance

\*Working environment: sinusoidal vibration: 5~9Hz: amplitude 3.5mm; 9~200Hz: acceleration 10m/s<sup>2</sup>; 3 axial direction, sweeping vibration 5 times in each direction, 10CT/min (1 octave/min).

\* Transportation environment: random vibration: 2~10Hz: 10m<sup>2</sup>/s<sup>3</sup>; 10~200Hz: 3m<sup>2</sup>/s<sup>3</sup>; 200~500Hz: 1m<sup>2</sup>/s<sup>3</sup>; 3 axial, 30min in each direction.

(Reference standard: ETS300019-2)

## 5.6 Impact Tolerance

\*Working environment: acceleration 250m / s<sup>2</sup>; pulse width 6ms; 3 axes 6 to each collision 500 times.

\* Transportation environment: acceleration 400m / s<sup>2</sup>; pulse width 6ms; 3 axes 6 to each collision 500 times.

(Reference standard: ETS300019-2)

## 5.7 Drop

Transportation environment: drop height 1m; bottom surface 1 time.

(Reference standard: ETS300019-2)

## 6.Size

H×W×D:83.8mm×112mm×257mm

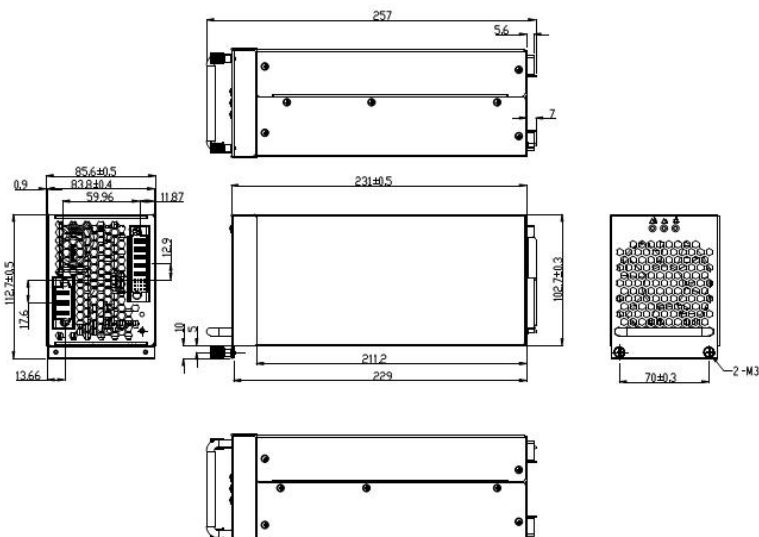

---

## 7. N.Weight

<4.8kg

## 8. Chassis IP Protection Level

IP20 (User normal maintenance operation surface)

## 9. Transportation and storage

The product should be placed in a warehouse that is affected by dry, ventilated and non-corrosive gases with a temperature of -10 ° C to 40 ° C and a relative humidity of not more than 80%.

The product has a strong packaging when transported. The outside of the box complies with the relevant national standards and should have signs such as “careful handling” and “moisture proof”. The box containing the product is allowed to be transported by any means of transport. Direct rain and snow strikes and mechanical impacts should be avoided during transportation.

## 10. Other Requirement

Item	Requirement	Note
noise	Less than 55dBa	
odor	not produce odor and harmful odor	
Components	All devices meet the de-rating	
Hot swap	Rectifier module for hot swap	
Failure isolation	After the rectifier module fails, it can be reliably separated from the system.	

## 11. MTBF

1\*10<sup>5</sup>h; 25°C, Rate Input,100% loading.

## 12. Connector PIN Definition

	Pin	Signal	Remark	Contact sequence
AC input	1	Rectifier module AC input	L	2
	2	Rectifier module protection Ground	PE	1

	3	Rectifier module AC input	N	2
DC output and Signal	1	Rectifier module address wire	ADDRES S0	3
	2	Rectifier module address wire	ADDRES S1	3
	3	Rectifier module share current wire	LOADS HARE+	3
	4	Rectifier forbidden	INHIBIT	4
	5	Rectifier output limited current function	CURRE NT LIMIT	3
	6	Rectifier output limited current function	CURRE NT LIMIT	3
	7	Rectifier address wire	ADDRES S2	3
	8	Rectifier address wire	ADDRES S3	3
	9	Rectifier address wire	LOADS HARE-	3
	10	RS485 Power +	+3.3V/+ 5V	3
DC output and Signal	11	RS485 Power-	+3.3V/+ 5VGND	3
	12	Rectifier communication wire	RS485-	3
	13	Rectifier address wire	ADDRES S4	3
	14	NC	NC	3
	15	Rectifier communication wire	RS485+	3
	16	Address Wire GND	ADDR_G ND	3
	As Figure	Pre- charge	Pre-Cha rge	1
	As Figure	Rectifier output 48V+	DC+	2
	As Figure	Rectifier output 48V+	DC+	2
As Figure	Rectifier output 48V-	DC-	2	
As Figure	Rectifier output 48V-	DC-	1	

(1) The description of the pin is as follows:

Block address definition: The module internally pulls up the address line. ADDRESS0~4 can be left floating outside the module or shorted to the address line GND. Shorting means "1", floating means "0", such as ADDRESS0 external and address If the line GND is shorted and the other address lines are left floating, the rectifier module address is 1. The address range of the rectifier module is 0 to 31.。

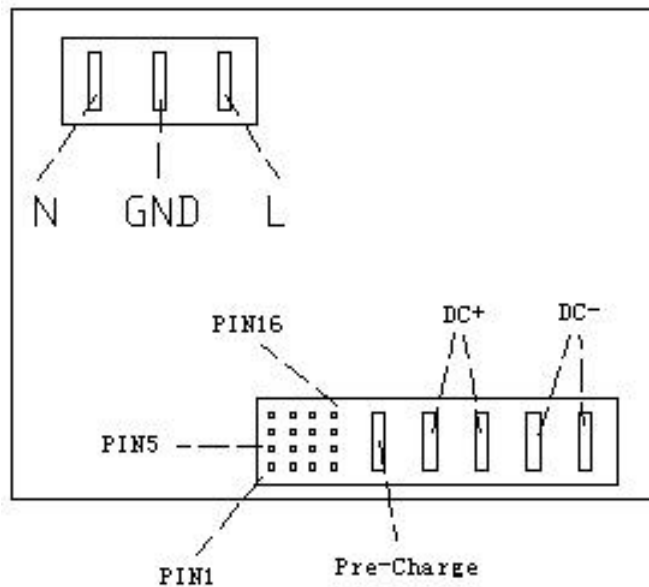

- (2) Pre-Charge pin is used to pre-charge the output capacitor inside the rectifier module when the rectifier module is hot swapped.。

## 13. Product Maintenance

### 13.1 Product free maintenance time

The free maintenance level of this product is Class B, and the free maintenance period (warranty period) is 1 year.

### 13.2 On-site maintenance

The power module has a hot swap function, and the on-site repair mode is module replacement.